



OPTI LEG PROCESSOR



foodmate

Poultry Processing Systems

The Foodmate OPTI Leg Processor is designed to anatomically remove the back from the saddle to create a back out whole leg. The unique design of the OPTI Leg Processor lets the saddles run straight through the machine and never change direction. The legs are pulled away from the back and there is no need to twist the back away from the hip sockets. This results in a smoother process, putting less strain on the backs and hocks, and improving yield. The machine can run a wide size range while

maintaining an optimal anatomical cut with minimal to no adjustments. Since the introduction in 2011, numerous customers have installed and benefited from the OPTI Leg Processor. All have reported very positive results with significant yield improvements while reducing rework caused by bone content. The OPTI Leg Processor can be installed in either a new Foodmate Cut-up System or it can easily be integrated into your existing frame or flex cut-up system.



Our mission is to innovate, automate and bring cost-effective solutions to the industry.

Key Benefits:

- Increases operations flexibility by accommodating a wide size range with minimal adjustments
- Reduces strain on the back with the elimination of the "turn"
- Reduces bone content
- Improves oyster retention
- Improves yield
- Increases the final drum and thigh presentation since the legs do not twist in the machine
- Increases bird size accommodations via height adjustment by the actuator

Foodmate is an equipment manufacturing company based in the Netherlands. Founded in 2006, we focus primarily on poultry processing, and we recently launched Foodmate Brasil, expanding our worldwide distribution into South America. Driven by research, paired with unmatched knowledge and decades of experience, it's our mission to innovate, automate and bring cost-effective solutions to the industry.

Our product line spans a wide assortment of processing equipment designed for live bird handling, killing and defeathering, eviscerating, chilling, weighing, cut-up systems, deboning and more.

Our team represents decades of industry knowledge and experience resulting in the engineering, development and implementation of new designs for our clients and their ever-changing needs.

Technical Specifications:

- Stainless steel frame and motor
- Motor (IP66) power is 0,75 kW
- Machine dimensions:
 - Length: 2099 mm
 - Width: 1054 mm
 - Height: 1608 mm
 - Weight: approx. 400 kg

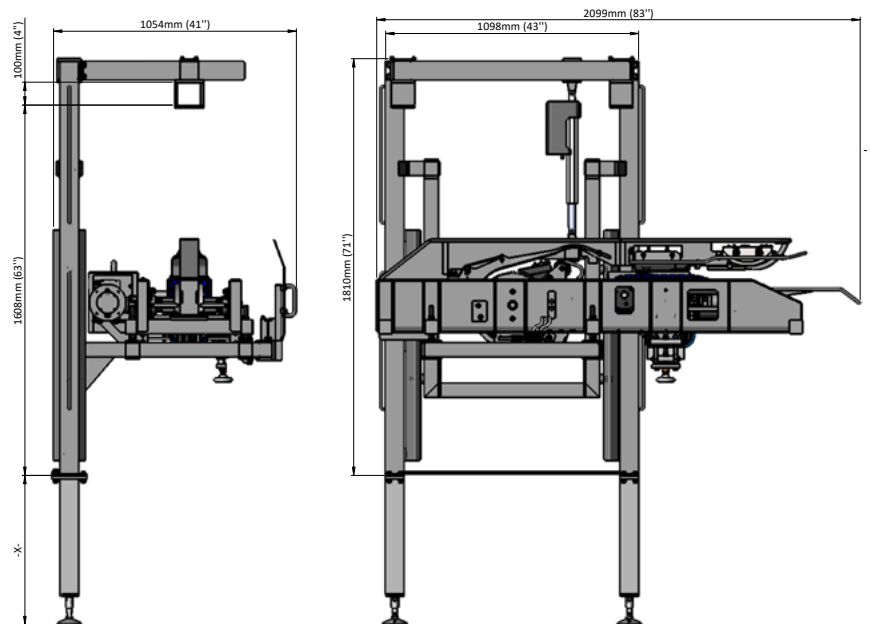

FOODMATE B.V.
The Netherlands
Phone: +31 186 630 240
info@foodmate.nl • www.foodmate.nl

FOODMATE POLSKA
Poland
Phone: +48 601 270 015
biuro@foodmate.nl • www.foodmate.pl

FOODMATE US
U.S.A.
Phone: +1 678 819 5270
info@foodmateusa.com • www.foodmateus.com

FOODMATE BRASIL
Brasil
Phone: +55 19 3308 7768
foodmatebrasil@foodmate.br.com • www.foodmate.nl



foodmate

FOODMATE UK LTD
United Kingdom
Phone: +44 33330 11110
info@foodmate.uk • www.foodmate.uk