



## MID WING CUTTER



**foodmate**

Poultry Processing Systems

The Foodmate Mid Wing Cutter is designed and developed to separate the mid wing piece (flapper/median) from the wing drumette, also known as the first joint piece. The machine cuts through the center joint of the chicken wings and can be used on chickens with or without the wingtips. The chickens are transported on shackles connected to a chain which is guided by rails. With the help of a

bar, the chickens are lifted and pressed against the rails, which positions the wings in the correct angle and position.

The wing centers are then cut by circular blades. The horizontal distance between the knives can be easily adjusted with the spindle. The module height is set throughout and the height of the blades can be adjusted according to the size of the chicken.

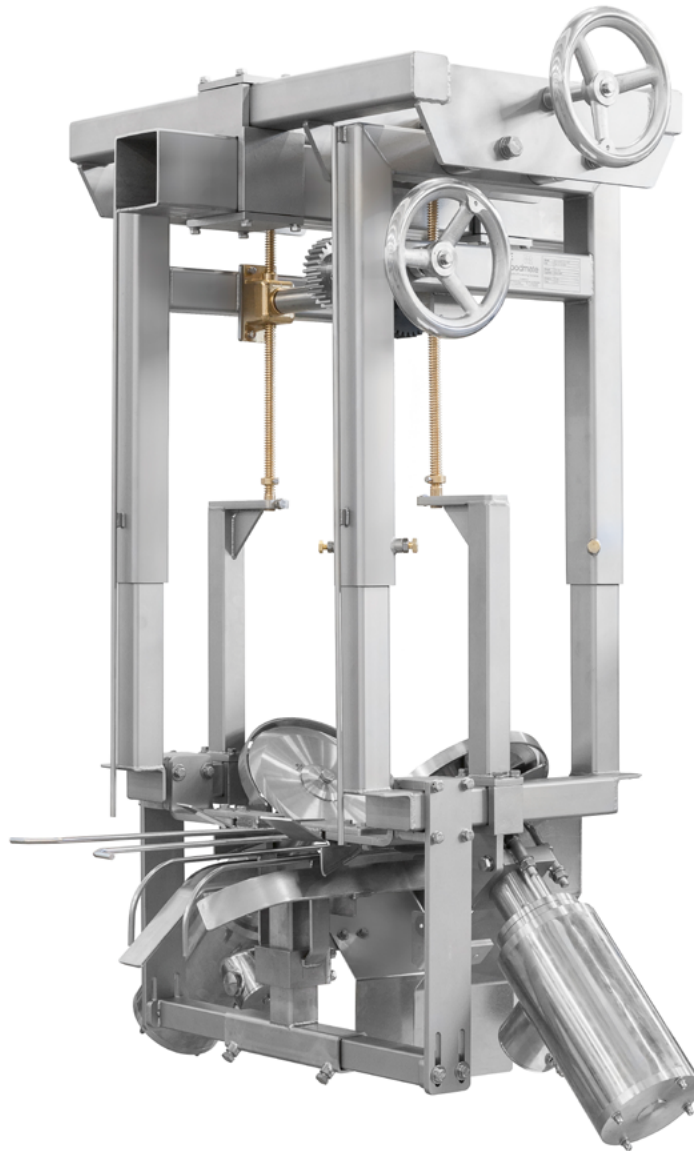

# MID WING CUTTER

## Key Benefits:

- Allows for a maximum of 6,000 birds per hour

Foodmate is an equipment manufacturing company based in the Netherlands. Founded in 2006, we focus primarily on poultry processing, and we recently launched Foodmate Brasil, expanding our worldwide distribution into South America. Driven by research, paired with unmatched knowledge and decades of experience, it's our mission to innovate, automate and bring cost-effective solutions to the industry.

Our product line spans a wide assortment of processing equipment designed for live bird handling, killing and de-feathering, eviscerating, chilling, weighing, cut-up systems, deboning and more.

Our team represents decades of industry knowledge and experience resulting in the engineering, development and implementation of new designs for our clients and their ever-changing needs.

## Technical Specifications:

- Stainless steel frame and motor
- Motor (IP66) power is 2 x 0,75 kW
- Machine dimensions:
  - Length: 728 mm
  - Width: 1106 mm
  - Height: 1308 mm
  - Weight: approx. 151 kg

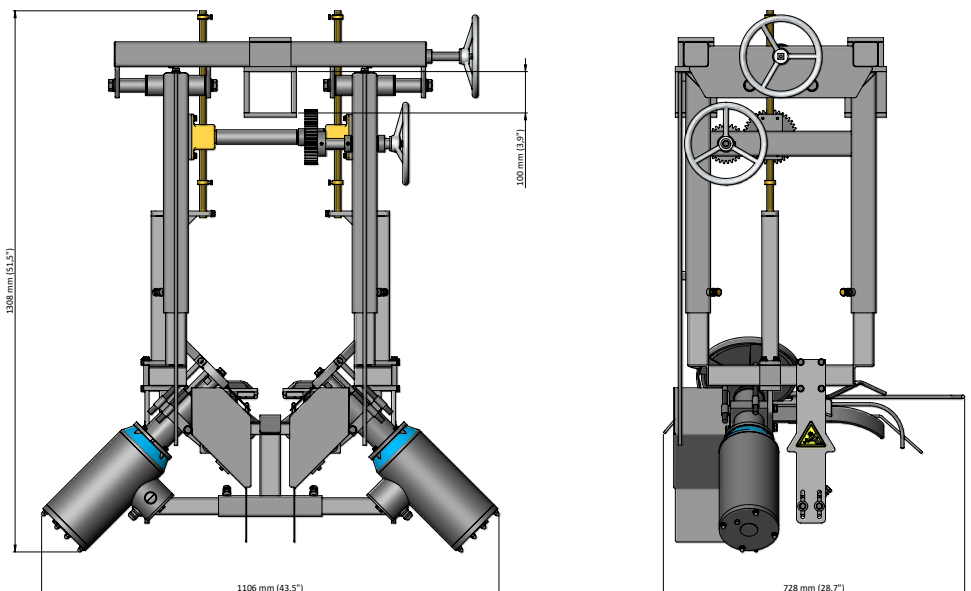

FOODMATE B.V.  
The Netherlands  
Phone: +31 186 630 240  
info@foodmate.nl • www.foodmate.nl

FOODMATE POLSKA  
Poland  
Phone: +48 601 270 015  
biuro@foodmate.nl • www.foodmate.pl

FOODMATE US  
U.S.A.  
Phone: +1 678 819 5270  
info@foodmateusa.com • www.foodmateus.com

FOODMATE BRASIL  
Brasil  
Phone: +55 19 3308 7768  
foodmatebrasil@foodmate.br.com • www.foodmate.nl

  
foodmate

FOODMATE UK LTD  
United Kingdom  
Phone: +44 33330 11110  
info@foodmate.uk • www.foodmate.uk