



HORIZONTAL SLICING MACHINE HSM -2



foodmate
Poultry Processing Systems

- Designed to feed newest dual lane portioners
- Two lanes with independent height adjustment and slice thickness
- Variable belt speed, max. 80 feet per min.
- Portion Removal to either side of the slicer
- Superior cut with short oscillating blade
- Long blade life
- No heat development, no cooling water needed
- Floating hold down belts
- Allan Bradley inverters for variable belt speed and slicing speed
- Designed for operator friendly and quick adjustments, machine controls on product loading side
- Properly guarded for safe operation, complies with latest safety and hygiene requirements
- Cleans easily with only slicing kits to be removed
- Extremely heavy-duty, designed for minimum downtime and maintenance
- Powerful gear motors
 - 1 x slicing unit
 - 1 x bottom conveyor belt
 - 1 x top compression belt
- Conveyor belts 330mm/13" wide with FDA quick connectors
- Made in stainless steel and other FDA approved non corrosive materials
- Water spray system for top and bottom belts optional



Our mission is to innovate, automate and bring cost-effective solutions to the industry.



HORIZONTAL SLICING MACHINE HSM -2

Key Benefits:

- Butterfly slicing kit for single chicken fillets
- For product height up to 50 mm / 2"
- For product width from 50 mm / 2" to 140 mm / 5 1/2"
- With slicing kits for up to 5 blades

Foodmate is an equipment manufacturing company based in the Netherlands. Founded in 2006, we focus primarily on poultry processing, and we recently launched Foodmate Brasil, expanding our worldwide distribution into South America. Driven by research, paired with unmatched knowledge and decades of experience, it's our mission to innovate, automate and bring cost-effective solutions to the industry.

Our product line spans a wide assortment of processing equipment designed for live bird handling, killing and de-feathering, eviscerating, chilling, weighing, cut-up systems, deboning and more.

Our team represents decades of industry knowledge and experience resulting in the engineering, development and implementation of new designs for our clients and their ever-changing needs.

Technical Specifications:

- Stainless steel frame and motor
- Motor (IP66) power supply: 3 x 2,7 kW

Machine dimensions:

- Length: 2924 mm
- Width: 1306 mm
- Height: 1320 mm
- Weight: approx. 550 kg

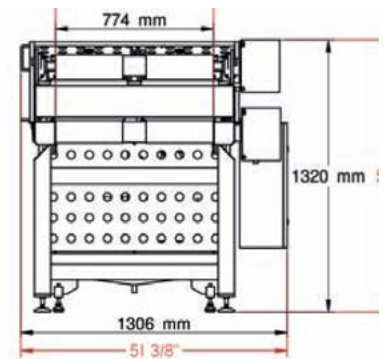
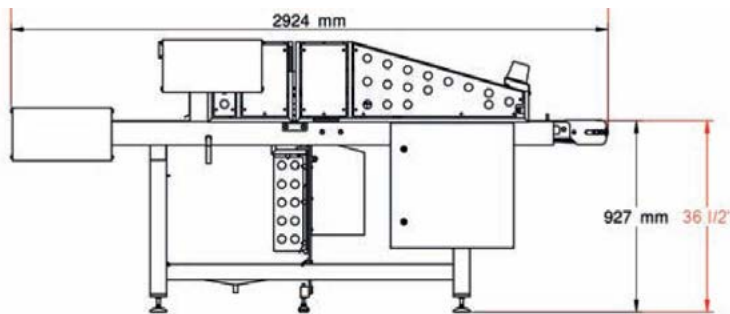

FOODMATE B.V.
The Netherlands
Phone: +31 186 630 240
info@foodmate.nl • www.foodmate.nl

FOODMATE POLSKA
Poland
Phone: +48 601 270 015
biuro@foodmate.nl • www.foodmate.pl

FOODMATE US
U.S.A.
Phone: +1 678 819 5270
info@foodmateusa.com • www.foodmateus.com

FOODMATE BRASIL
Brasil
Phone: +55 19 3308 7768
foodmatebrasil@foodmate.br.com • www.foodmate.nl



foodmate

FOODMATE UK LTD
United Kingdom
Phone: +44 33330 11110
info@foodmate.uk • www.foodmate.uk