



FM 6.2 (T) CHICKEN THIGH DEBONER



foodmate

Poultry Processing Systems

The Foodmate 6.2 (T) chicken thigh deboner has been specially developed for the smaller chicken processing companies. The key design features are machine safety CE and hygiene.

The machine has to be loaded by 1 operator with 2 hands, which means that 2 anatomic thighs will be placed on the loading positions. After the product has been placed in position the operator should

press 2 buttons at the same time so that crush hazard of body parts (hands) will be avoided. The thigh deboner works according to the "diaphragm principle". After the bone has been separated from the meat, the meat should be removed manually from its loading positions and stored in 2 crates. The bone automatically falls down into the lower positioned crate (crates are not included).





FM 6.2 (T) CHICKEN THIGH DEBONER

Key Benefit:

- Allows for a maximum of 1,200 thighs per hour

Foodmate is an equipment manufacturing company based in the Netherlands. Founded in 2006, we focus primarily on poultry processing, and we recently launched Foodmate Brasil, expanding our worldwide distribution into South America. Driven by research, paired with unmatched knowledge and decades of experience, it's our mission to innovate, automate and bring cost-effective solutions to the industry.

Our product line spans a wide assortment of processing equipment designed for live bird handling, killing and de-feathering, eviscerating, chilling, weighing, cut-up systems, deboning and more.

Our team represents decades of industry knowledge and experience resulting in the engineering, development and implementation of new designs for our clients and their ever-changing needs.

Technical Specifications:

- Stainless steel frame
- Machine dimensions:
 - Length: 1730 mm
 - Width: 911 mm
 - Height: 1580 mm
 - Weight: approx. 175 kg

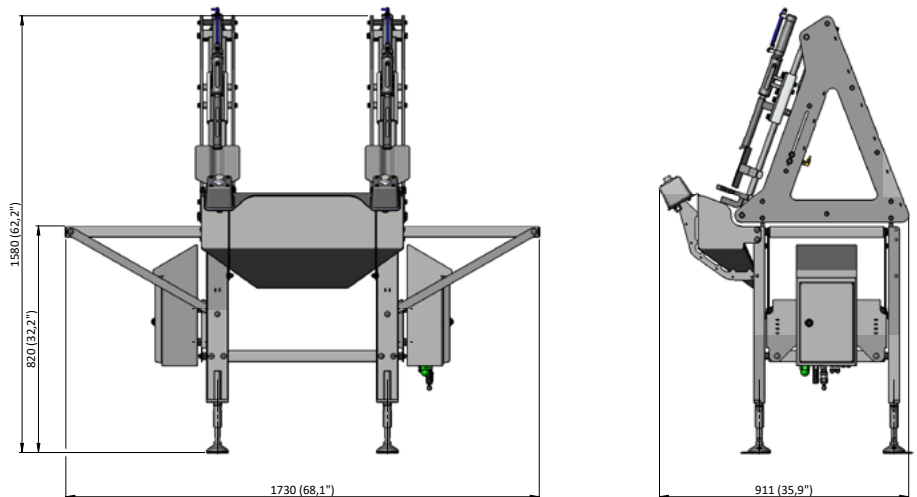

FOODMATE B.V.
The Netherlands
Phone: +31 186 630 240
info@foodmate.nl • www.foodmate.nl

FOODMATE POLSKA
Poland
Phone: +48 601 270 015
biuro@foodmate.nl • www.foodmate.pl

FOODMATE US
U.S.A.
Phone: +1 678 819 5270
info@foodmateusa.com • www.foodmateus.com

FOODMATE BRASIL
Brasil
Phone: +55 19 3308 7768
foodmatebrasil@foodmate.br.com • www.foodmate.nl

foodmate

FOODMATE UK LTD
United Kingdom
Phone: +44 33330 11110
info@foodmate.uk • www.foodmate.uk