



## CROSS HALVING MACHINE



**foodmate**

Poultry Processing Systems

The Foodmate Cross Halving Machine addresses problems commonly found with single bladed front halving machines. Using two blades instead of one large blade gives a better straight cut across the hips and gives more

control over the number of ribs that stay attached to the front half. There is no need for a pre-cutter with the Cross Halving Machine and it contains a simple construction with no belts and easy maintenance.



Our mission is to innovate, automate and bring cost-effective solutions to the industry.



# CROSS HALVING MACHINE

## Key Benefits:

- Allows for consistent and straight cuts
- Eliminates the need for a pre-cutting machine
- Allows for easy adjustment due to the simple construction
- Integrates easily into existing frame or flex cut-up system
- Allows for a maximum of 6,000 birds per hour

Foodmate is an equipment manufacturing company based in the Netherlands. Founded in 2006, we focus primarily on poultry processing, and we recently launched Foodmate Brasil, expanding our worldwide distribution into South America. Driven by research, paired with unmatched knowledge and decades of experience, it's our mission to innovate, automate and bring cost-effective solutions to the industry.

Our product line spans a wide assortment of processing equipment designed for live bird handling, killing and de-feathering, eviscerating, chilling, weighing, cut-up systems, deboning and more.

Our team represents decades of industry knowledge and experience resulting in the engineering, development and implementation of new designs for our clients and their ever-changing needs.

## Technical Specifications:

- Stainless steel frame and motor
- Motor (IP66) power is 2 x 0,75 kW
- Machine dimensions:
  - Length: 882 mm
  - Width: 694 mm
  - Height: 882 mm
  - Weight: approx. 132 kg

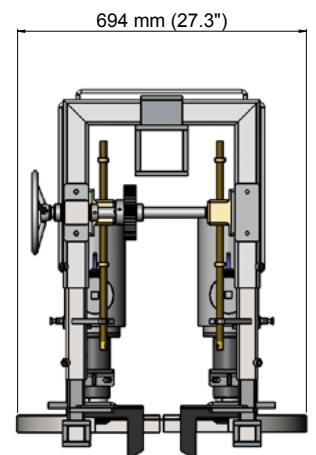
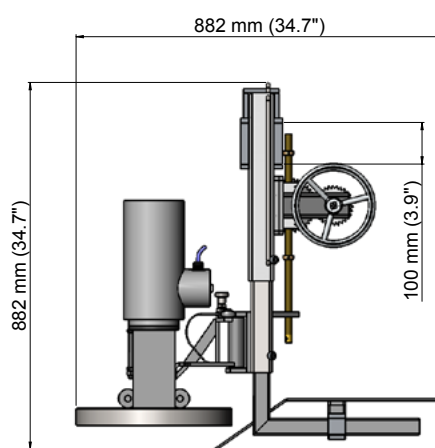

FOODMATE B.V.  
The Netherlands  
Phone: +31 186 630 240  
info@foodmate.nl • www.foodmate.nl

FOODMATE POLSKA  
Poland  
Phone: +48 601 270 015  
biuro@foodmate.nl • www.foodmate.pl

FOODMATE US  
U.S.A.  
Phone: +1 678 819 5270  
info@foodmateusa.com • www.foodmateus.com

FOODMATE BRASIL  
Brasil  
Phone: +55 19 3308 7768  
foodmatebrasil@foodmate.br.com • www.foodmate.nl

  
foodmate

FOODMATE UK LTD  
United Kingdom  
Phone: +44 33330 11110  
info@foodmate.uk • www.foodmate.uk