



## AUTOMATIC VENT CUTTER



**foodmate**

Poultry Processing Systems

The Foodmate Automatic Vent Cutter is used to release the bursa fabricius and then vent and position it on the back of the bird, in various types of poultry. By utilizing cylinder blades of the correct diameter in relation to the product size/weight, a perfect vent cut is made, thus avoiding weight loss and damage to the intestines. The machine is fitted with 16 vent cutting units that, by means of tail rollers and breast holders, position the

birds in the correct way prior to vent cutting. The machine provides adjustable infeed timing and height adjustments for different weight ranges. The cylinder blades are line driven and after each cycle, cylinder blades are then cleaned by water. It is stainless steel and food approved nylon constructed, and driven by the overhead conveyor system.

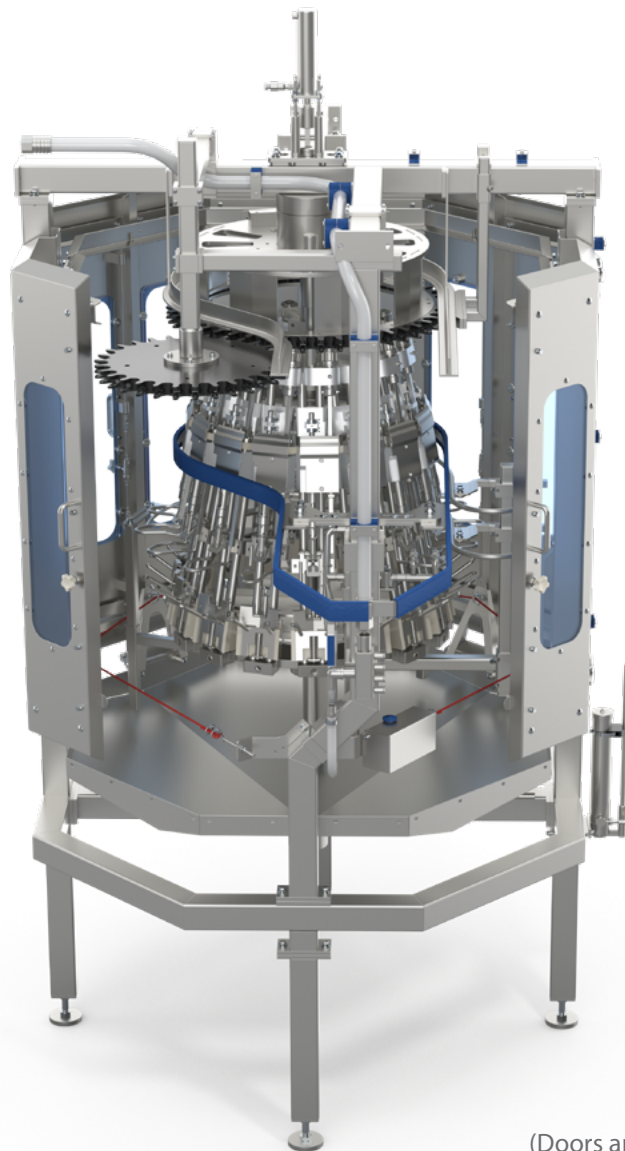

(Doors are optional)



# AUTOMATIC VENT CUTTER

## Key Benefit:

- Allows for a maximum of 9,000 birds per hour

Foodmate is an equipment manufacturing company based in the Netherlands. Founded in 2006, we focus primarily on poultry processing, and we recently launched Foodmate Brasil, expanding our worldwide distribution into South America. Driven by research, paired with unmatched knowledge and decades of experience, it's our mission to innovate, automate and bring cost-effective solutions to the industry.

Our product line spans a wide assortment of processing equipment designed for live bird handling, killing and de-feathering, eviscerating, chilling, weighing, cut-up systems, deboning and more.

Our team represents decades of industry knowledge and experience resulting in the engineering, development and implementation of new designs for our clients and their ever-changing needs.

## Technical Specifications:

- Stainless steel frame
- Units: 16
- Pitch: 6"
- Rotation: CW/CCW
- Conveyor type:
  - Pipe
  - T-track
- Machine dimensions
  - Length: 1624 mm
  - Width: 1624 mm
  - Height: 2843 mm
  - Weight: approx. 896 kg

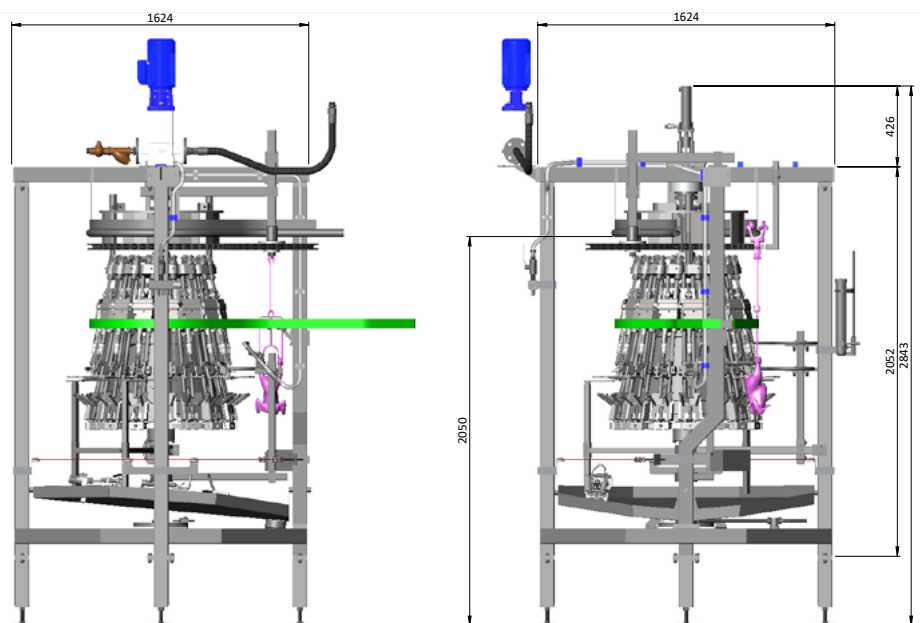

FOODMATE B.V.  
The Netherlands  
Phone: +31 186 630 240  
info@foodmate.nl • www.foodmate.nl

FOODMATE POLSKA  
Poland  
Phone: +48 601 270 015  
biuro@foodmate.nl • www.foodmate.pl

FOODMATE US  
U.S.A.  
Phone: +1 678 819 5270  
info@foodmateusa.com • www.foodmateus.com

FOODMATE BRASIL  
Brasil  
Phone: +55 19 3308 7768  
foodmatebrasil@foodmate.br.com • www.foodmate.nl



FOODMATE UK LTD  
United Kingdom  
Phone: +44 33330 11110  
info@foodmate.uk • www.foodmate.uk